

Airborne™ Embedded Serial/Ethernet to Wireless LAN (module) Evaluation & Design Kit

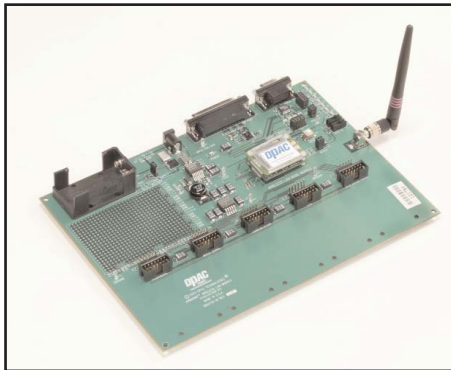

Evaluate Airborne's Performance in Just One Kit

The Evaluation & Design Kit provides software and utilities for a developer to quickly and easily operate and evaluate the Airborne Embedded Wireless Device Server module or the Airborne Embedded Ethernet Bridge module.

The kit consists of a printed circuit board assembly with the module. All of the necessary hardware, software and documentation are provided to quickly power-up and operate the module. Designed as an evaluation platform for the module, the board has a variety of exposed interfaces offering flexible options for connection to OEM applications and test configurations. Among the I/O connections are digital and RS-232 UART ports, multiple GPIO ports, analog input ports an optional SPI bus port or Ethernet.

Applications

The Evaluation Board features a series of switches and LED's used for LAN interaction. They indicate power, RF link, link activity and the status of several other functions of the module. The board includes a battery and holder that enables portable evaluation of the module in a variety of locations and physical

circumstances, such as outdoors, in a factory, or in office environments behind cubicles and around walls. Typical evaluation criteria might include: receive signal strength, selected bit rate, actual data rate, bit error rate and lost packet count. These can be observed and recorded for later review. A monopole antenna can be attached and is included with the kit.

Accompanying the Evaluation & Design Kit is a CD containing the Evaluation Utility, and comprehensive module and kit documentation. The easy to follow User's Guide provides all the information needed to set up, configure, and operate the Evaluation Kit and software. The Evaluation Software provides a unified user interface with a rich set of evaluation and performance measurement functions. This is an excellent tool that makes it quick and easy to evaluate the features and benefits of the Airborne™ modules.

KEY FEATURES

- Complete kit for the evaluation of Airborne Embedded Wireless Device Server module or Airborne Embedded Wireless Bridge module
- Development tool for test and debug of applications
- Battery operation enables portable evaluation
- Multiple options for flexible I/O connectivity
- Monopole high-gain antenna included
- Evaluation and test sample software provided
- Full documentation and User's Guide

Model Selection Guide

Model No.	Interface						WiFi	Security		
	UART	RS-232	RS-422/485	SPI	Digital & Analog I/O	10 Base-T Ethernet	802.11b	WEP (64 & 128 bit)	WPA	LEAP*
WLNБ-EK-DP001	<i>Evaluation & Design Kit for serial modules (below) includes Wireless Access Point</i>									
WLNБ-EK-DP003	<i>Evaluation & Design Kit for serial modules (below) does not include Wireless Access Point</i>									
WLNБ-AN-DP101	●	●			●		●	●	●	
WLNБ-AN-DP102				●	●		●	●	●	
WLNБ-AN-DP501	●	●			●		●	●	●	●
WLNБ-AN-DP502				●	●		●	●	●	●
WLNБ-SE-DP101	●	●	●				●	●	●	
ABEB-ET-DP103	<i>Evaluation & Design Kit for Ethernet modules (below) includes Wireless Access Point</i>									
WLNБ-ET-DP101						●	●	●	●	
WLNБ-ET-DP501						●	●	●	●	●

*Web server not present with LEAP

Block Diagram

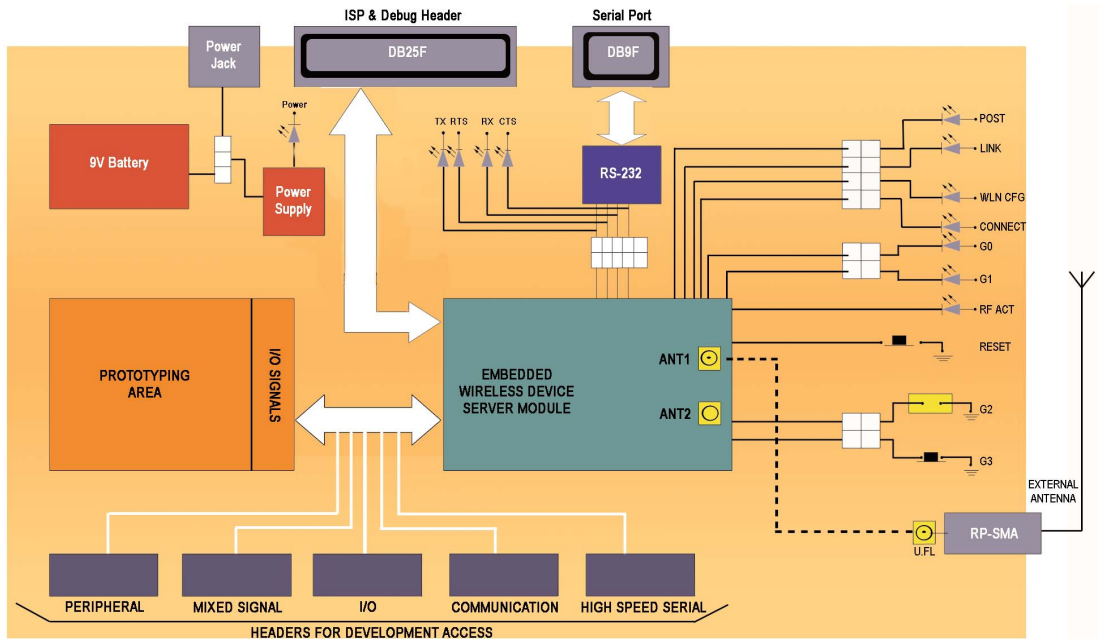

Technical Features

- Logic analyzer access headers
- Five development access connectors
- Reset switch
- Two LEDs for I/O status
- Breadboard for prototyping
- 5V and 3.3V power available (6.5W)
- Two utility switches for I/O interaction
- Jumpers provide I/O isolation

Contents

- Airborne™ Embedded Wireless Device Server or Airborne™ Embedded Wireless Bridge Module
- Evaluation Board (6" x 9")
- Access Point Router
- Quick Start Guide
- Power Supply
- Serial Port Cable - DB9F to DB9M
- ISP Cable - DB25M to DB25M
- External Antenna
- 9 Volt Battery
- Software CD includes:
 - Evaluation utilities
 - Kit user's guide
 - Module firmware
 - Release notes

